



Traditional Gutter

Installation Guide for Traditional Gutter

4 COMMERCE WAY, ARDEN, NC 28704 USA
800-892-9173 828-676-1700
OMGEDGESYSTEMS.COM



EdgeSystems



Installation Guide for Traditional Gutter - Flat Strap Type

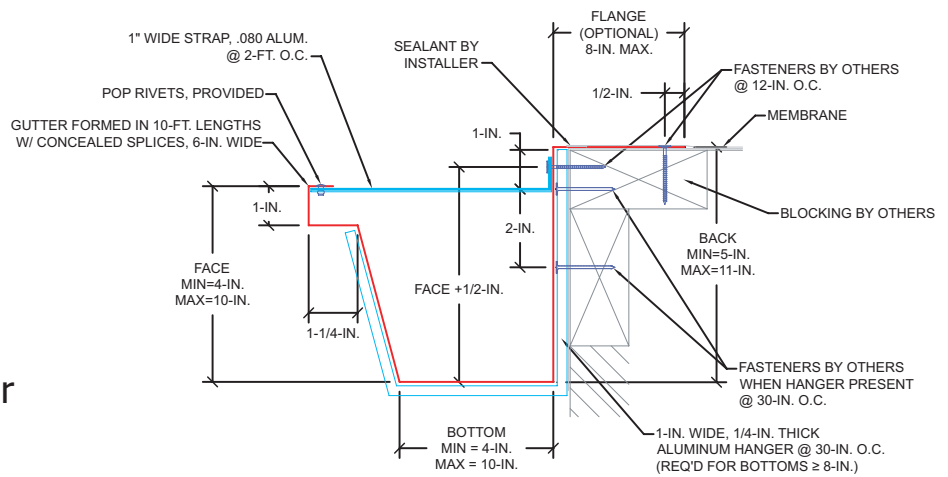

FOR MASONRY APPLICATIONS, PLEASE CONTACT OMG.

CONTACT OMG FOR APPROPRIATE RECOMMENDATIONS NEEDED TO MEET/EXCEED ANSI/SPRI/GT-1 DESIGN CRITERIA

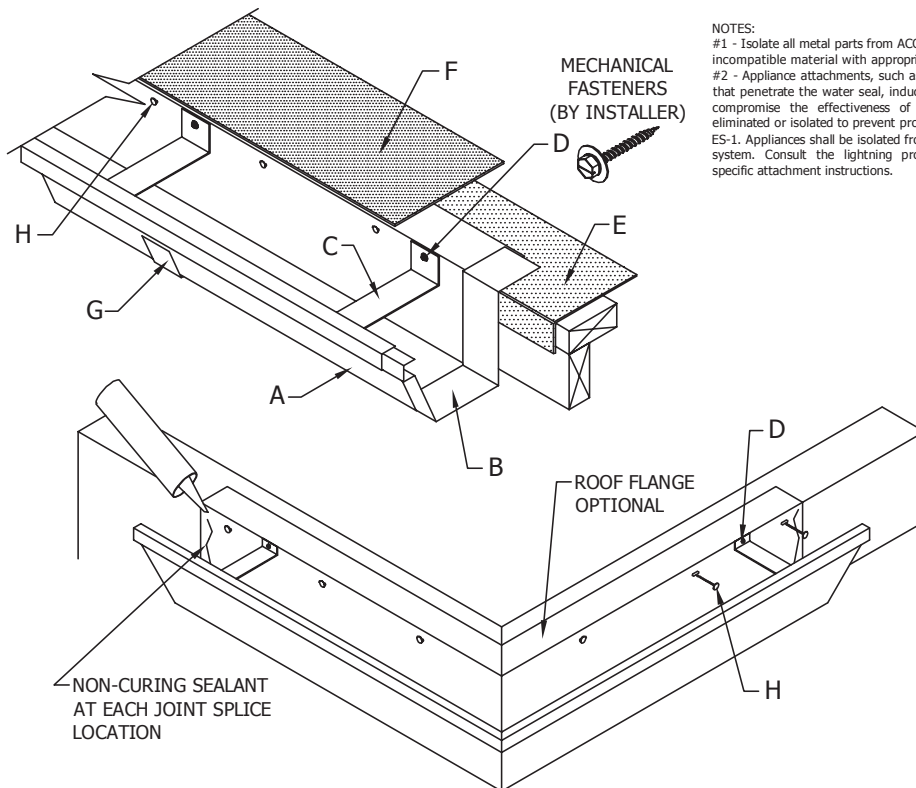

NOTES:

- #1 - Isolate all metal parts from ACQ treated wood or other galvanically incompatible material with appropriate membrane material.
- #2 - Appliance attachments, such as lightning rods, signs, or antennae that penetrate the water seal, induce a galvanic reaction, or otherwise compromise the effectiveness of the roof edge system, shall be eliminated or isolated to prevent problems per section 8.0 of ANSI/SPRI ES-1. Appliances shall be isolated from or not attached to the roof edge system. Consult the lightning protection system manufacturer for specific attachment instructions.

- A. Formed Gutter**
10'-0" Lengths
- B. Concealed Joint Splice**
6" Wide at All Joints
- C. Gutter Strap**
(24" On Center Typ.)
- D. Mechanical Fastener**
Located at Each Hole & Gutter Strap
(24" On Center Typ., By Installer)

- E. Base Ply Membrane**
(By Installer)
- F. Strip In Membrane**
(By Installer)
- G. Gutter Hanger**
(Optional, by Design)
- H. Gutter Fastener**
(By Installer)

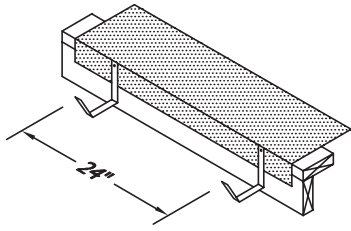

STEP 1: Installing Hanger (Optional, by Design)

Locate appropriate hangers and install @ 24" o.c. using mechanical fasteners in pre-punched holes.

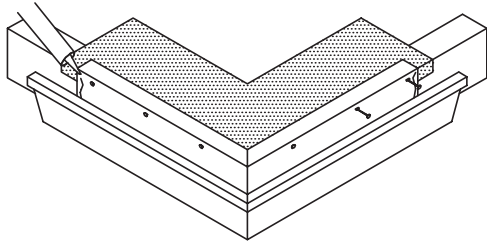

STEP 2: Installing Gutter Miters

Locate the miters and concealed joint splices for the appropriate corners. Install the miter by nailing through pre-punched holes with gutter fasteners (by installer). Apply a heavy bead of non-curing sealant to inside of each miter end. Install a concealed joint splice into each miter end. Pop-Rivet the joint splice as instructed in step 3.

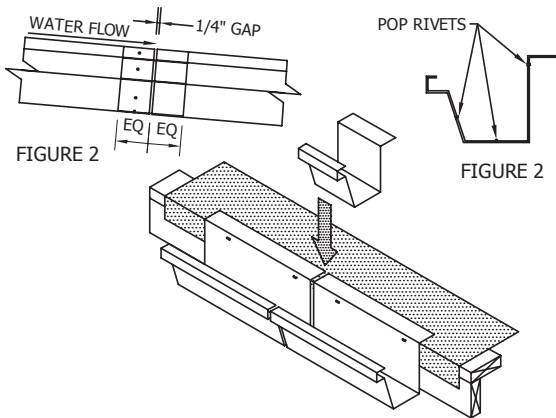

STEP 3: Installing Gutter Straight Lengths and Joint Splices

Begin from the end caps/miters working inward to the center. **Allow 1/4" gap between gutter sections for thermal expansion.** Review lengths of all straight pieces prior to cutting to avoid creating relatively short sections of cap adjacent to full length section. Locate the joint splice for the appropriate gutter. Apply a continuous bead of non-curing sealant to both sides of the joint. Slide the joint splice down into the gutter. Secure the joint splice in place by pop riveting it on the high side of the joint (Figure 1) on the 3 surfaces as shown in Figure 2. There must be a joint splice at every joint.

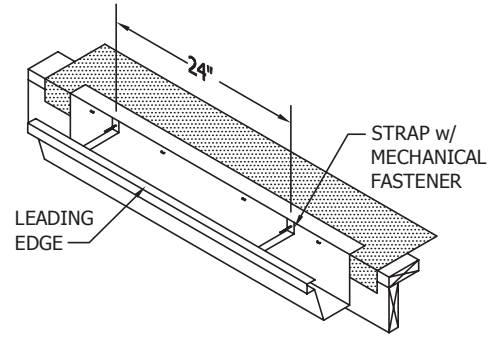

STEP 4: Installing Straps

Slide strap into leading edge of gutter as shown. Install @ 24" o.c. using mechanical fasteners in pre-punched holes.

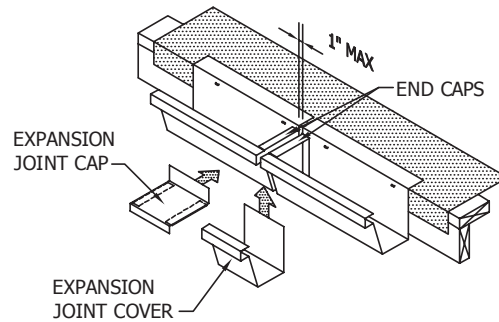

STEP 5: Installing Expansion Joints (If Required)

Install expansion joint in location as specified on roof plan(s). An expansion joint will consist of (2) pre-fabricated end caps, (1) expansion joint cap and (1) expansion joint cover. Gap the end caps at 1" max. Slide the joint cover onto the gutter, then pop rivet the joint cover in the same locations as shown in FIGURE 2. Place the joint cap over the end cap lips and center the joint cap over the gap, secure in place using the 1-1/2" ss ring shank nails (provided).

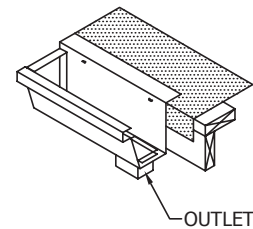

STEP 6: Installing Downspout Outlets

Determine outlet locations and field cut hole in gutter bottom. Insert starter tube outlet (see installation guide for downspout) and fasten with 2 rivets in each flange and seal, with non-curing sealant. Pop-rivets are provided by manufacturer.